

"My CME Hammermill produces 60% more output than my other brand with the same HP."

-John B

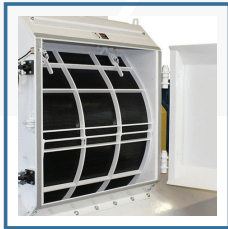

# CME

**COLORADO MILL EQUIPMENT**  
USA PELLETING, MILLING & SCREENING SOLUTIONS

## SPECIFICATIONS

<b>Motor</b> 200, 300, 400 HP	<b>Weight</b> 8,000 – 10,650 LBS
<b>Screen Size</b> .033" to 1"	<b>Aspiration Req.</b> 6,000 CFM
<b>Screen Area</b> 4,700"	<b>Hammers</b> 110
<b>Dimensions (IN)</b> 130" L x 70" W x 85" H	

Capacity/HR: Please call for the capacity of your application

## MILL-HMX400 HAMMERMILL

*Lifetime Engineering, Technical & Application Support*

Our Hammermax Series flagship model, the MILL-HMX400 hammermill, sized at 40" x 44", is designed to accommodate a motor power range of 200 HP to 400 HP. Its versatility allows it to be tailored for both coarse and fine grinding applications. The Mill-HMX400 is stocked and assembled in our Colorado Manufacturing plant.

 *Our equipment is engineered in the USA and supported in the USA*

## RULE BREAKING TECHNOLOGY

- ▶ Hammermax proprietary grinding wear plates
- ▶ Side forklift slots and lifting hooks for easy installation
- ▶ Built-in airbase for pneumatic movement
- ▶ Safety interlocks
- ▶ Powder coated with FDA-approved materials
- ▶ CME's Signature 1-Year Manufacturer's Warranty

## COMMON MATERIALS

Alfalfa	Plastics	Wood
Corn	Poultry Litter	Wood Grill Pellets
General Feed	Recyclables	Fertilizer
Hemp / Cannabis	Soybean Meal	Carbon
Oats	Wheat	

## INDUSTRIES

Fertilizer	Ethanol	Rendering
Animal Feed	Hemp/Cannabis	Wood Processing
Aquaculture	Hops	Lab
Chemicals	Pet Food	Food Processing

## OPTIONS

- ▶ Change Parts Required: New Screen, New Hammers
- ▶ New Rotary Pocket Feeder
- ▶ Magnet
- ▶ Vibration Switch
- ▶ Isolation Pad Set
- ▶ Safety Control Panel
- ▶ 575V Motors

# MILL-HMX400 HAMMERMILL

*\*OUTPUTS CAN VARY. PLEASE CALL FOR CAPACITY ON YOUR PRODUCTS.*

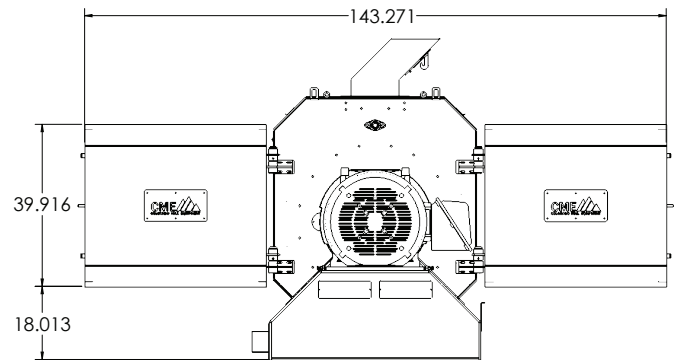
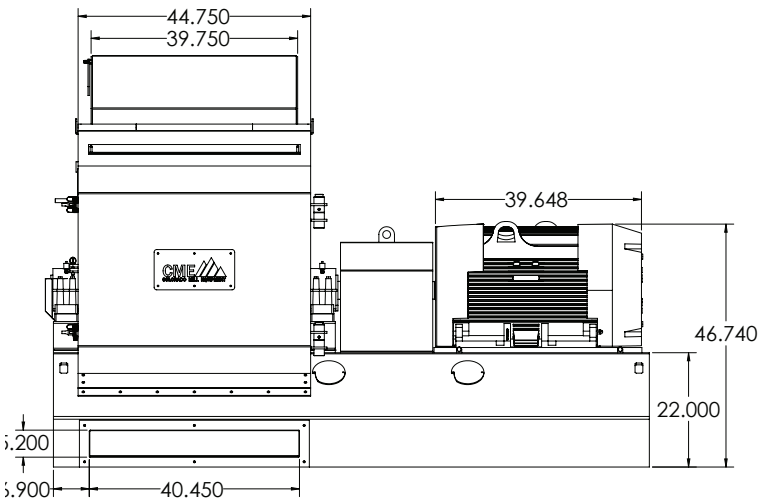
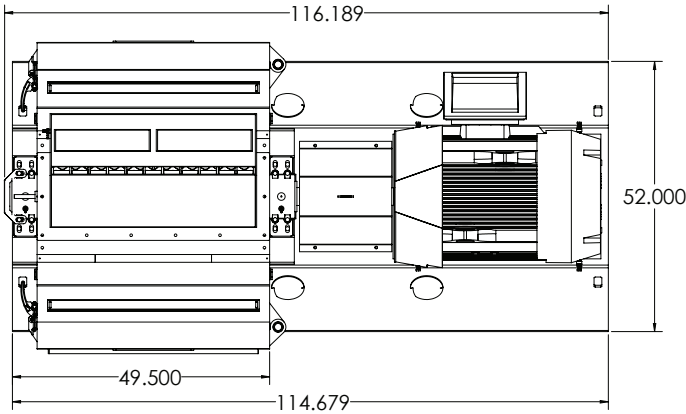

**Sawdust**

**Cornmeal**

**Ground Alfalfa**

**Ground Hemp**

**Bone Meal**

