



MILL- R400 PELLET MILL

Lifetime Engineering, Technical & Application Support

Part of CME's Millennium Series, the Mill-R400 Pellet Mill stands as a robust, full-sized production unit boasting one of the highest horsepower-to-surface area ratios in its class.

 *Our equipment is engineered in the USA and supported in the USA*

RULE BREAKING TECHNOLOGY

- ▶ 7.2" inner diameter roller bearing that can be tightened when worn
- ▶ 72" major pullet for maximum torque
- ▶ Kevlar/Aramid belts rate at over 600hp
- ▶ Forklift slots front to back and side to side
- ▶ Sloped force feeder for maximum flow
- ▶ Mechanical sealed door to feed cone for zero bypass
- ▶ Quick install die with self-aligning studs and tapered wear rings
- ▶ All US steel base that is cut, formed, welded, and machined in the USA
- ▶ Dual cylindered knife post for easy position reset
- ▶ Adjustable wipers

SPECIFICATIONS

Motor 400 HP	Capacity/HR 8,000- 40,000 LBS
Dimensions (IN) 110" L, 130 W 120" H	Die Inner Dia. 26" Ring
Weight 20,000- 22,000 LBS	

COMMON MATERIALS

Alfalfa	Plastics	Wood Grill Pellets
Corn	Poultry Litter	Fertilizer
General Feed	Soybean Meal	Carbon
Hemp / Cannabis	Wheat	
Oats	Wood	

INDUSTRIES

Fertilizer	Ethanol	Rendering
Alfalfa	Hemp/Cannabis	Wood Processing
Animal Feed	Hops	Lab
Aquaculture	Pet Food	Food Processing
Chemicals	Recycling & Plastics	

OPTIONS

- ▶ Change Parts Required: New Die
- ▶ Change Parts Required: New Roller Assembly Set
- ▶ Stainless Conditioner
- ▶ Stainless Variable Pitch Feeder
- ▶ Stainless Heavy Duty Force Feeder
- ▶ Magnet (requires purchase of a Force Feeder)
- ▶ Food Grade Grease
- ▶ Auto Lubrication System
- ▶ Isolation Pad Set
- ▶ Safety Control Panel

MILL- R400 PELLET MILL

**OUTPUTS CAN VARY. PLEASE CALL FOR CAPACITY ON YOUR PRODUCTS.*

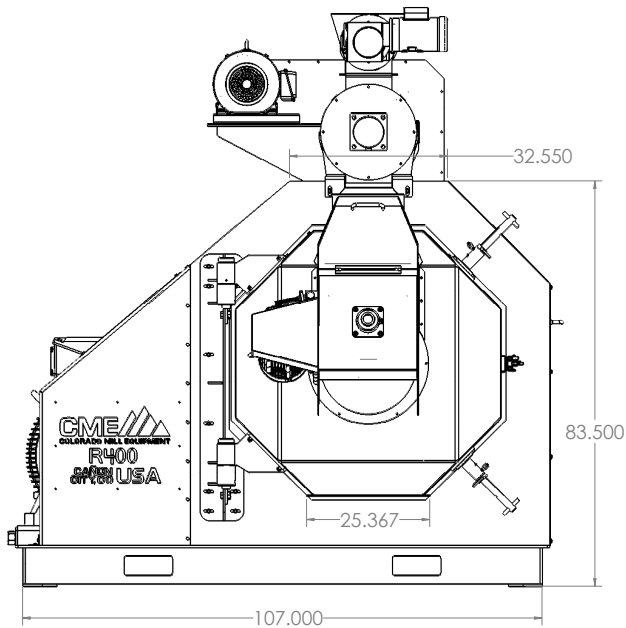
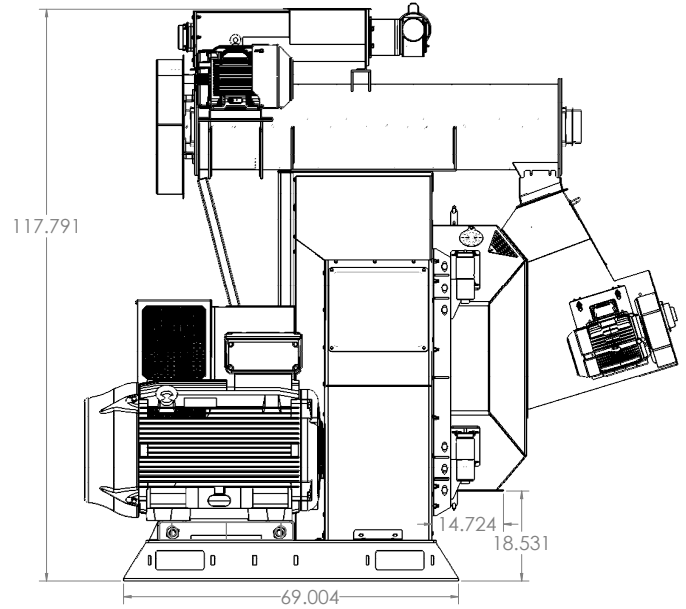
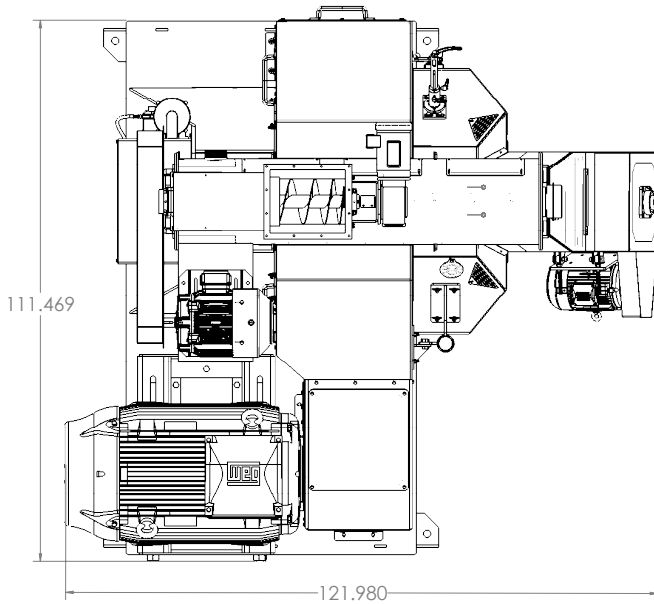

Fertilizer

Plastic

Alfalfa

Carbon

Wood

